

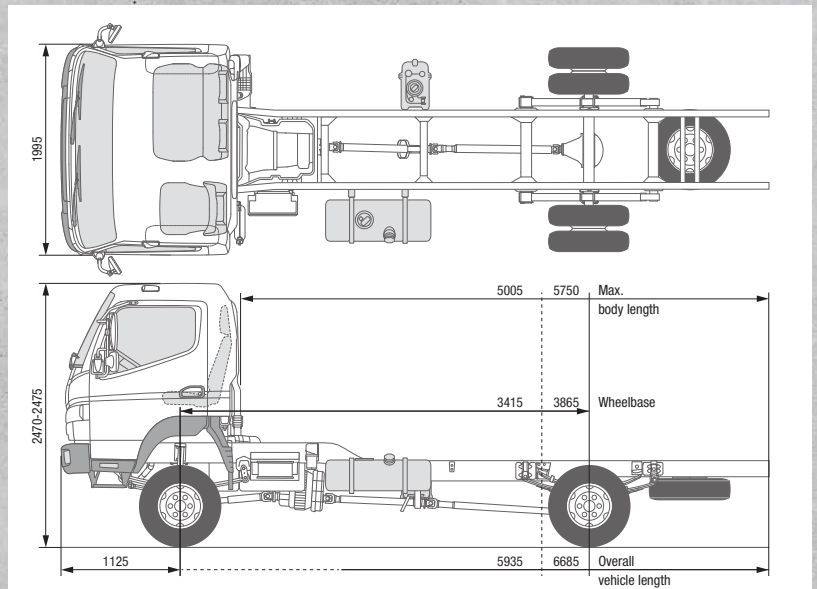

CANTER 6C18 4x4

LHD



MODEL / VEHICLE TYPE

	6C18 4x4	
Cab type / crew	Comfort, single cab / 3	
Model variant	46891512	46891712
FUSO model code	FGB71EL6SEUU	FGB71GL6SEUU

DIMENSIONS mm

Wheelbase		3415	3865
Overall length		5935	6685
Cab length			1625
Width overall			2025
Cab width			1995
Height overall		2475	2470
Track width	Front / rear	1665 / 1560	
Frame height (at end of frame)		890	895
Cab to rear axle		2890	3340
Cab to end of frame		4285	5035
Max. body length**		5005	5750
Frame width			750
Front overhang			1125
Rear overhang		1395	1695
Front axle to front of body			625
Recommended distance cab to body			100

WEIGHTS kg

Empty weight*		2820	2840
	Front* / rear*	1860 / 960	1875 / 965
Minimum vehicle weight		2905	
Gross vehicle weight / gross combination weight		6500 / 10,000	
Axle loads	Front / rear	2800 / 5125	2800 / 5070
Towed weight	Braked / unbraked	3500 / 750	
Chassis load bearing capacity		3680	3660

CALCULATED OUTPUT

Max. speed	km/h	130	
Min. turning circle (m)	Kerb to kerb	13.5	15.1
	Wall to wall	14.9	16.5

GROUND CLEARANCES AND APPROACH/DEPARTURE ANGLES

Ground clearance under axles	Front / rear	210 / 185	
Approach/departure angles	front / rear	35° / 25°	



CANTER 6C18 4x4 LHD

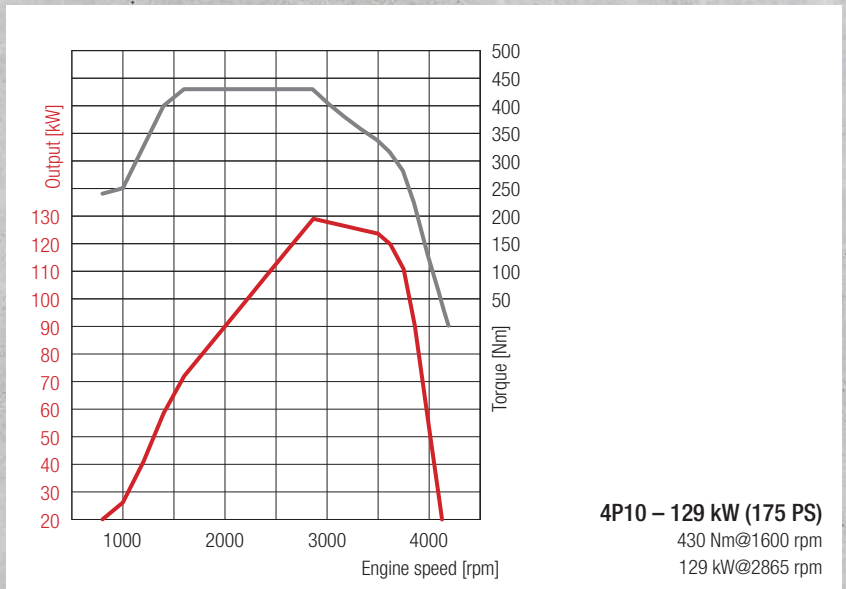

4P10 – 129 kW (175 PS)
 430 Nm@1600 rpm
 129 kW@2865 rpm

ENGINE (Euro VI)

Type	Water-cooled four-stroke diesel engine with turbocharger, intercooler and direct injection		
No. of cylinders	4/in-line		
Capacity	2998 cm ³		
Peak output	129 kW (175 hp) / 2865 rpm		
Rated torque	430 Nm / 1600 rpm		
Diesel particulate filter	Service life approx. 300,000 km		
Alternator	Alternating current 12V, 140A		
Exhaust gas aftertreatment	SCR + DPF		
PTO (optional)	Type	31 kW with flange	31 kW for directly connected pumps
	Torque at peak output [Nm]:	196 Nm	
	Gear ratios	1:0.644	1:0.638
	Engine speed at peak output	1500 rpm	

POWERTRAIN

Transmission / all-wheel drive	Type	Manual gearbox, 5 forward gears, 1 reverse gear	
	Gear ratio	5.494 - 3.193 - 1.689 - 1.000 - 0.723 Rev. 5.494	
	Torque split 4x4	60% front / 40% rear	
Rear axle gear ratio	Ratio	4.875	

CHASSIS

Front axle / rear axle	Model	F200TW / R035T	
	Load-bearing capacity front/rear	2800 kg / 5125 kg (3415 mm)	2800 kg / 5070 kg (3865 mm)
Tyres		205/75R17.5C 124/122 M	
		Twin tyres at rear, tyres with optimised rolling resistance	
Wheel		17.5 x 6.00 - 127 - 9t - 6 wheel bolts	
Steering		LHD	
		Recirculating-ball steering with power assist, tilting telescopic steering column with steering-wheel lock	
Brake	Service brake	Hydraulic with vacuum power assist, dual-circuit with load-dependent brake proportioning valve at rear wheels	
	Front / rear	Drum brake (320 x 75.2L) / drum brake (320 x 110)	
	Parking brake	Mechanical expanding brake on drive shaft at rear of transmission	
	Auxiliary brake	Exhaust brake (50 kW)	
Suspension	Front / rear	Semi-elliptic leaf spring with shock absorber and stabiliser	
Frame	Type	Ladder-type frame with reinforcements and crossmembers	
Fuel tank capacity		100 litres	
Electrical system – batteries		12 Volt (100 AH - 760 A(EN))	

* including coolant, oil, 90% fuel, spare wheel, tools and driver weighing 75 kg; ** calculated maximum value. Should be checked depending on the body installed and the particular application
 Subject to change without notice. The information in this data sheet should be considered approximate. The illustrations may show accessories and special equipment not part of the standard specification. This data sheet may also contain models and support services not available in certain countries.