



# The Mercedes-Benz Sprinter.

Chassis Cab and Chassis Crewcab models.

Prices effective from 01 January 2023.

Mercedes-Benz





RETURN TO START

## Contents

> <b>Model overview</b>	<b>3</b>
> <b>Models</b>	
Sprinter Chassis Cab	4
Sprinter Chassis Crewcab	5
> <b>Colours and Upholstery</b>	<b>6</b>
> <b>MBUX infotainment system</b>	<b>7</b>
> <b>Equipment</b>	<b>8</b>
> <b>Engine and gearbox</b>	<b>20</b>
> <b>Fuel consumption</b>	<b>21</b>
> <b>Weights and payloads</b>	<b>23</b>
> <b>Dimensions</b>	<b>24</b>
> <b>List prices</b>	<b>28</b>
> <b>Approved Used</b>	<b>29</b>
> <b>Finance Options</b>	<b>30</b>
> <b>Aftercare</b>	<b>31</b>

### **Please note**

This document provides information about the model range line-up and specifications of the Sprinter. It also contains key details about options, economy and performance of all variants. Details are correct at time of publication and are subject to revision. Any images used in this document may not reflect UK specification and are for illustrative purposes only. Images may show optional equipment which does not form part of UK standard specification.



RETURN TO START

# The Mercedes-Benz Sprinter Chassis Cab and Chassis Crewcab.



**Chassis Cab** - 3 seats



**Chassis Crewcab** - 6 seats

## Available in 2 emission categories:

Euro 6d (Light duty)  
Euro VI (Heavy duty)

2 van models:



**L2**



**L3** Chassis Crewcab only

2 lengths:



**PROGRESSIVE**

1 trim:

Discover more about the other Mercedes-Benz Sprinter diesel models in our range:

- ▶ [The Sprinter Panel Van](#)
- ▶ [The Sprinter Crew Van](#)
- ▶ [Sprinter Ready to work conversions](#)

Discover more about the Mercedes-Benz Sprinter electric models in our range:

- ▶ [The eSprinter Panel Van](#)

# The Sprinter Chassis Cab.

The Progressive trimline offers the following features:

## Interior

- Height & rake adjustable steering wheel
- Comfort overhead control panel
- Driver's armrest
- Dual passenger seat
- Eco Start/Stop

## Exterior

- Headlight assistant
- Heat-insulating glass

## Safety, security and connectivity

- Active Brake ASSIST
- ADAPTIVE ESP\*
- Additional USB-C
- ATTENTION ASSIST
- Crosswind ASSIST
- Cruise control/Speed limiter
- Double locks
- Integrated connected Thatcham approved alarm system
- Keyless start
- MBUX multimedia system with 7-inch touch screen
- USB-C and Bluetooth® interface, WiFi hotspot, Apple CarPlay/Android Auto and a DAB radio

From £39,610\*

\* Based on a Sprinter 315 Chassis L2 FWD - Euro 6d

- **2 lengths available**  
L2: 5,986mm (FWD) or 5,886mm (RWD)  
L3: 6,695mm (RWD)
- **FWD and RWD options available**

➤ [Arrange a test drive at your nearest Dealership](#)



The Mercedes-Benz Sprinter 4

Sprinter Chassis Cab	Sprinter Chassis Crewcab	MBUX	Equipment	Engine and gearbox	Fuel consumption	Weights and payloads	Dimensions	List prices	Approved Used	Finance Options	Aftercare
----------------------	--------------------------	------	-----------	--------------------	------------------	----------------------	------------	-------------	---------------	-----------------	-----------

# The Sprinter Chassis Crewcab.

The Progressive trimline offers the following features:

## Interior

- Height & rake adjustable steering wheel
- Comfort overhead control panel
- Driver's armrest
- Dual passenger seat
- Eco Start/Stop

## Exterior

- Headlight assistant
- Heat-insulating glass

## Safety, security and connectivity

- Active Brake ASSIST
- ADAPTIVE ESP®
- Additional USB-C
- ATTENTION ASSIST
- Crosswind ASSIST
- Cruise control/Speed limiter
- Double locks
- Integrated connected Thatcham approved alarm system
- Keyless start
- MBUX multimedia system with 7-inch touch screen
- USB-C and Bluetooth® interface, WiFi hotspot, Apple CarPlay/Android Auto and a DAB radio

### Additional features included with the Crewcab:

- Additional passenger doors
- Passenger seat compartment – 3-seater bench
- Panelling under the roof

From £43,780\*

\* Based on a Sprinter 315 Crewcab L3 RWD – Euro VI (and Euro 6d)

- **1 length available**  
L3: 6,695mm
- **RWD only**

➤ [Arrange a test drive at your nearest Dealership](#)



Image shows upgraded Black ARNCO man-made leather

The Mercedes-Benz Sprinter 5

Sprinter Chassis Cab	Sprinter Chassis Crewcab	MBUX	Equipment	Engine and gearbox	Fuel consumption	Weights and payloads	Dimensions	List prices	Approved Used	Finance Options	Aftercare
----------------------	--------------------------	------	-----------	--------------------	------------------	----------------------	------------	-------------	---------------	-----------------	-----------

# Colours and upholstery.



RETURN TO START

## Solid paints



Arctic White (Standard)



Jupiter Red



Steel Blue



Blue Grey



Jet Black

## Metallic paints



Cavansite Blue Metallic



Tenorite Grey Metallic



Selenite Grey Metallic



Obsidian Black Metallic



Iridium Silver Metallic

## Interior upholstery



Maturin black fabric (Standard)

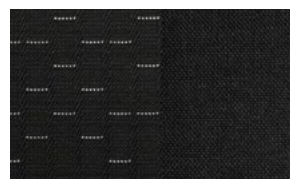

Caluma black fabric

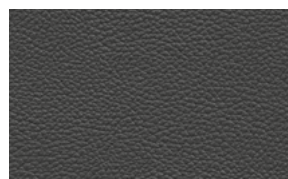

Black ARTICO man-made leather

➤ [For paint pricing, see page 8](#)

➤ [For upholstery pricing, see page 12](#)

# MBUX – the Mercedes-Benz User Experience infotainment system.



RETURN TO START

The state-of-the-art MBUX technology comes with a high resolution 7-inch touchscreen fitted as standard, offering intuitive touch control. You can also upgrade to a 10.25-inch display with HD resolution for additional features.

## 7-inch (standard) features

The state-of-the-art MBUX technology comes as standard in every Sprinter and offers a wealth of features:

- Works in conjunction with steering wheel touch pads, for quick and easy fingertip access
- Apple CarPlay/Android Auto, a DAB radio and Wi-Fi hotspot\*
- Allows text messages and navigation data to be sent between the driver and vehicle manager when the van is stationary to increase productivity and efficiency
- Additional services such as Live Traffic information can be accessed via Mercedes me. More information about Mercedes me is [available here](#).

## 10.25-inch (optional upgrade) additional features

- 'Hey Mercedes', Voice Command Operation
- What3words – a geocoded map system offering more accurate location services – integrated into the in-van navigation systems. Drivers with compatible models can now say or type in a three-word address to get directions to a precise 3m x 3m location, anywhere in the world.

➤ [For more information on optional features, see page 15](#)



# Equipment (standard and optional overview).



RETURN TO START

Every Sprinter model comes with a host of standard features, plus a range of optional equipment you can add to enhance your van.

Key: ● Standard ○ Optional — Not available

Equipment	Description	Option code	Front-wheel drive	Rear-wheel drive	Basic Price excl. VAT	Basic Price incl. VAT
			PROGRESSIVE	PROGRESSIVE		
<b>Exterior Features</b>						
<b>Axle</b>	<b>Front axle with increased load capacity</b>	A50	●	○	£275.00	£330.00
	<b>Rear axle springs made of glass-fibre-reinforced plastic</b>	C83	○	○	£250.00	£300.00
<b>Exhaust</b>	<b>Exhaust straight to chassis rear</b>	K60	○	○	£120.00	£144.00
<b>Fuel Tank</b>	<b>50L Fuel tank</b> <small>Note: FWD only.</small>	K11	○	—	£0.00	£0.00
	<b>65L Fuel tank</b> <small>Note: FWD only.</small>	K12	●	—	£0.00	£0.00
	<b>71L Fuel tank</b> <small>Note: RWD only.</small>	K13	—	●	£0.00	£0.00
	<b>92L Fuel tank</b> <small>Note: FWD only.</small>	KB8	○	—	£280.00	£336.00
	<b>93L Fuel tank</b>	KB7	—	○	£285.00	£342.00
	<b>Diesel filler cap in red</b>	K56	○	○	£20.00	£24.00
	<b>Fuel filter with water separator</b>	KL5	●	●	£0.00	£0.00
	<b>Lockable AdBlue filler cap</b>	K53	○	○	£20.00	£24.00
<b>Mud flaps</b>	<b>Front mud flaps</b>	P47	○	○	£55.00	£66.00
	<b>Rear mud flaps</b>	P48	○	○	£55.00	£66.00
<b>Paint</b>	<b>Chrome-plated radiator grille</b> <small>Includes: Radiator grille frame in vehicle colour (CN2).</small>	FK3	○	○	£215.00	£258.00
	<b>Optional colours, solid or metallic finish.</b>	—	○	○	£595.00	£714.00
	<b>Radiator grille frame in vehicle colour</b>	CN2	○	○	£100.00	£120.00
<b>Power Take Off</b>	<b>Constant engine speed control</b> <small>Includes: Parameterizable special module (ED5).</small>	M53	○	○	£510.00	£612.00
	<b>Variable electronic engine speed control</b> <small>Includes: Parameterizable special module (ED5).</small>	MT4	○	○	£555.00	£666.00
	<b>Engine front power take-off with bracket for additional alternator</b>	N62	—	○	£300.00	£360.00
	<b>Engine power take-off at front with carrier for additional refrigerant compressor</b>	N63	—	○	£300.00	£360.00

Changes to individual option availability and combinations may occur depending on vehicle specification choices and the continuing evolution and adaptation of our product range. These changes may not be immediately reflected in this document as they occur, but will be introduced at the next revision opportunity.



# Equipment (standard and optional overview).



RETURN TO START

Equipment	Description	Option code	Front-wheel drive	Rear-wheel drive	Basic Price excl. VAT	Basic Price incl. VAT
			PROGRESSIVE	PROGRESSIVE		
<b>Exterior Features (cont.)</b>						
Power Take Off (cont.)	Power take off counter shaft MB, (2c)	N05	–	○	£960.00	£1,152.00
	Power take off counter shaft MB, (2b)	N07	–	○	£1,085.00	£1,302.00
Suspension	<b>Suspension packages are available on select models, depending on application and variant. Please consult your local Dealer.</b>					
	<b>Air suspension – run-on module 1 h</b> Note: Only available in conjunction with comfort suspension air suspension (CB2).	C1N	–	○	£175.00	£210.00
	<b>Air suspension for rescue vehicles</b> Note: Only available in conjunction with comfort suspension air suspension (CB2).	C1R	–	○	£95.00	£114.00
	<b>Air suspension – pre-installation for control switch in rear</b> Note: Only available in conjunction with comfort suspension air suspension (CB2).	C1V	–	○	£75.00	£90.00
	<b>Air suspension – actuation, speed signal</b> Note: Only available in conjunction with comfort suspension air suspension (CB2).	C2A	–	○	£95.00	£114.00
	<b>Air suspension – control switch in instrument panel</b> Note: Only available in conjunction with comfort suspension air suspension (CB2).	C2I	–	○	£130.00	£156.00
	<b>Air suspension – valve for emergency filling</b> Note: Only available in conjunction with comfort suspension air suspension (CB2).	C2V	–	○	£120.00	£144.00
	<b>Comfort air suspension</b>	CB2	–	○	£2,395.00	£2,874.00
	<b>Deletion, vehicle lowering</b> Note: Only available for vehicles in the weight classes 3,000 kg and 3,500 kg with rear-wheel drive.	CW2	○	○	£0.00	£0.00
	<b>Longitudinal member reinforcement</b>	Q11	●	●	£0.00	£0.00
	<b>Reinforced shock absorbers</b>	C47	○	○	£110.00	£132.00
	<b>Stabilisation level I</b> Note: Not available for weight class 4,100 kg with front-wheel drive. Replaces CF2 to CF3 from previous Sprinter.	CB7	●	●	£0.00	£0.00
	<b>Stabilisation level II</b> Note: replaces CF4 and CF5 from previous Sprinter.	CB8	○	○	£725.00	£870.00
	<b>Suspension for comfort and cargo protection</b>	CB1	○	○	£335.00	£402.00
	<b>Vibration damper</b>	CT1	–	○	£90.00	£108.00
Tyres	<b>Summer tyres</b>	RM7	●	●	£0.00	£0.00
	<b>All-season tyres</b>	RM0	○	○	£105.00	£126.00
	<b>Mud and slush tyres</b>	RM1	○	○	£205.00	£246.00

● Standard ○ Optional – Not available

# Equipment (standard and optional overview).



RETURN TO START

Equipment	Description	Option code	Front-wheel drive	Rear-wheel drive	Basic Price excl. VAT	Basic Price incl. VAT
			PROGRESSIVE	PROGRESSIVE		
<b>Exterior Features (cont.)</b>						
Tyres (cont.)	Tyres without name of make	RD9	●	●	£0.00	£0.00
	Resistance-optimised tyres	RR0	●	●	£0.00	£0.00
	Continental tyres	RF1	○	○	£0.00	£0.00
	Goodyear (90) tyres	RF9	○	○	£0.00	£0.00
	Michelin (80) tyres	RF8	○	○	£0.00	£0.00
	Pirelli (50) tyres	RF5	○	○	£0.00	£0.00
	Tyres 225/65 R16 C	RN5	●	○	£0.00	£0.00
	Tyres 225/75 R16 C	RG8	–	–	£0.00	£0.00
	Tyres 235/65 R16 C	RH2	–	●	£0.00	£0.00
	Tyres 235/60 R17 C	RH3	–	○	£0.00	£0.00
	Tyre pressure monitoring systems	RY2	○	○	£255.00	£306.00
	Steel wheels in arctic white	RM2	○	○	£60.00	£72.00
Steel wheels 6.5 J x 16	RS3	●	●	£0.00	£0.00	
Wheels	Light-alloy wheels 6.5 J x 16	RL5	○	○	£685.00	£822.00
	Light-alloy wheels, 6.5 J x 16 in black	RM3	○	–	£795.00	£954.00
	Light-alloy wheels 6.5 J x 17 Includes: Tyres 235/60 R17 C (RH3).	RL7	–	○	£750.00	£900.00
	Full wheel cover	RD8	○	○	£100.00	£120.00
	Spare wheel	R87	●	●	£0.00	£0.00
	Omission of spare wheel	R020	○	–	–£55.00	–£55.00
	Spare wheel bracket below frame end	R65	●	●	£0.00	£0.00
	Jack	Y36	●	–	£0.00	£0.00
Hydraulic Jack	Y43	–	●	£0.00	£0.00	

● Standard ○ Optional – Not available

# Equipment (standard and optional overview).



RETURN TO START

Equipment	Description	Option code	Front-wheel drive	Rear-wheel drive	Basic Price excl. VAT	Basic Price incl. VAT
			PROGRESSIVE	PROGRESSIVE		
<b>Interior Features</b>						
<b>Gearbox</b>	<b>6-speed manual transmission</b>	GE9	●	—	£0.00	£0.00
	<b>ECO Gear 360 6-speed manual transmission</b>	GD8	—	●	£0.00	£0.00
	<b>9G-TRONIC automatic gearbox</b>	G43	—	○	£2,070.00	£2,484.00
	<b>9G-TRONIC automatic gearbox (FWD)</b>	GK8	○	—	£2,030.00	£2,436.00
<b>Grab handles</b>	<b>Grab handles for driver's and co-driver's doors</b>	T75	○	○	£65.00	£78.00
	<b>Grab handle for inner seat, two-seater</b>	S78	○	○	£45.00	£54.00
<b>Heating</b>	<b>Heat insulation</b>	H04	○	○	£105.00	£126.00
	<b>Electric hot-air auxiliary heater</b>	HH2	○	○	£190.00	£228.00
	<b>Heater booster system</b>	HZ9	○	○	£510.00	£612.00
	<b>Hot-water auxiliary heater</b>	H12	○	○	£660.00	£792.00
	<b>Pre-installation for additional heat exchanger</b> Includes: Sliding door (T93) and Hot-water auxiliary heater (H12).	H88	○	○	£845.00	£1,014.00
	<b>Radio remote control for hot-water auxiliary heater</b> Includes: Hot-water auxiliary heater (H12).	HY1	○	○	£915.00	£1,098.00
	<b>THERMOTRONIC automatic climate control system</b> Includes: Rain sensor (JF1).	HH4	○	○	£2,215.00	£2,658.00
	<b>TEMPMATIC semi-automatic climate control system</b>	HH9	—	○	£1,050.00	£1,260.00
	<b>TEMPMATIC semi-automatic climate control system</b> Includes: FWD includes Alternator 14V/230A (M48).	HH9	○	—	£1,215.00	£1,458.00
	<b>Ventilation system with filter</b>	H81	○	○	£75.00	£90.00
<b>Seating</b>	<b>Armrest for driver's seat</b>	S22	●	●	£50.00	£60.00
	<b>Armrest for co-driver's seat</b>	S25	○	○	£45.00	£54.00
	<b>Armrest, driver's and co-driver's door</b>	S28	○	○	£35.00	£42.00
	<b>Adjustable co-driver's seat</b>	S04	○	○	£0.00	£0.00
	<b>Comfort driver's seat</b>	SB1	○	○	£115.00	£138.00
	<b>Comfort co-driver's seat</b>	SB2	○	○	£115.00	£138.00
	<b>Convenience head restraint, driver's seat</b>	SK0	○	○	£60.00	£72.00
	<b>Convenience head restraint, co-driver's seat</b>	SK1	○	○	£60.00	£72.00
	<b>Co-driver's double seat</b>	S23	●	●	£0.00	£0.00

● Standard ○ Optional — Not available

# Equipment (standard and optional overview).



RETURN TO START

Equipment	Description	Option code	Front-wheel drive	Rear-wheel drive	Basic Price excl. VAT	Basic Price incl. VAT
			PROGRESSIVE	PROGRESSIVE		
<b>Interior Features (cont.)</b>						
Seating (cont.)	<b>Deletion of co-driver seat, seatbox and seatbelt system</b>	S91, S99, SW1	○	○	£0.00	£0.00
	<b>Deletion of passenger compartment seats, if crew cab</b>	S92	–	–	-£95.00	-£95.00
	<b>Driver's seat</b>	S02	●	●	£0.00	£0.00
	<b>Driver's seat plus</b>	SB9	○	○	£25.00	£30.00
	<b>Driver's seat electrically adjustable</b> Includes: Lumbar support, driver's seat (SE5), Fabric Caluma black (VF4) and Heated seat for driver (H16).	SF1	○	○	£1,215.00	£1,458.00
	<b>Co-driver's seat electrically adjustable</b> Includes: Seat heating for co-driver (H15) and Heated driver's seat electrically adjustable (SF1).	SF2	○	○	£2,370.00	£2,844.00
	<b>Heated seat for driver</b>	H16	○	○	£165.00	£198.00
	<b>Lumbar support, driver's seat</b> Includes: Comfort driver's seat (SB1).	SE5	○	○	£65.00	£78.00
	<b>Lumbar support, co-driver's seat</b> Includes: Comfort co-driver's seat (SB2).	SE4	○	○	£180.00	£216.00
	<b>Re-enforced seat base</b>	S86	–	–	£110.00	£132.00
	<b>Seat heating for co-driver</b> Includes: Heated seat for driver (H16).	H15	○	○	£330.00	£396.00
	<b>Seat belts orange, driver and co-driver</b>	S62	○	○	£35.00	£42.00
	<b>Suspension seat, comfort version, driver's seat</b> Note: Only available in conjunction with Driver's seat frame, low (S87).	SB3	○	○	£405.00	£486.00
<b>Suspension seat, comfort version, co-driver's seat</b> Note: Only available in conjunction with Driver's seat frame, low (S87).	SB4	○	○	£405.00	£486.00	
Trim	<b>Seat trim upholstery – ARTICO man-made leather, black</b>	VF6	○	○	From £60.00 depending on variant	
	<b>Seat trim upholstery – Maturin black fabric</b>	VF7	●	●	£0.00	£0.00
	<b>Seat trim upholstery – Caluma black fabric</b>	VF4	○	○	From £60.00 depending on variant	
	<b>Rear cab wall lining</b>	V07	○	○	£140.00	£168.00

● Standard ○ Optional – Not available

# Equipment (standard and optional overview).



RETURN TO START

Equipment	Description	Option code	Front-wheel drive	Rear-wheel drive	Basic Price excl. VAT	Basic Price incl. VAT
			PROGRESSIVE	PROGRESSIVE		
<b>Interior Features (cont.)</b>						
<b>Steering wheel</b>	<b>Leather steering wheel and leather gearshift lever</b>	CL2	○	○	£210.00	£252.00
	Leather steering wheel Note: For automatics only. Includes: 9G-TRONIC PLUS (G43) and HOLD function (BH1).	CL3	○	○	£2,235.00	£2,682.00
	Multifunction steering wheel	C6L	●	●	£0.00	£0.00
	Steering wheel adjustable for height and tilt	CL1	●	●	£0.00	£0.00
<b>Storage</b>	Cup holders front - x4	FG8	○	○	£0.00	£0.00
	Hinged lid for centre stowage compartment	FJ1	●	●	£0.00	£0.00
	Hinged lid for stowage compartments left and right	FJ5	○	○	£100.00	£120.00
	Multifunction box on two-seater, stowable. Only in conjunction with: Co-driver's double seat (S23).	Y2A	○	○	£95.00	£114.00
	Omission of shelf above windscreen	FW6	–	○	£0.00	£0.00
	Omission of stowage compartment under cockpit	F3W	–	○	£0.00	£0.00
	Pre-installation for switch panel	E3J	●	●	£0.00	£0.00
	Shelf above windscreen	FF5	●	●	£0.00	£0.00
	Single-size slot at front under roof liner	FF8	○	○	£65.00	£78.00
	Stowage compartment underneath cockpit	FJ4	●	●	£0.00	£0.00
	Stowage net on driver's seat backrest	SZ7	○	○	£45.00	£54.00
	Stowage net on co-driver's seat backrest	SZ8	○	○	£45.00	£54.00
	Lockable unit in stowage compartment over windscreen	FQ6	○	○	£50.00	£60.00
<b>Technology Software and Electrics</b>						
<b>Alternators</b>	Alternator 14 V / 175 A	=	●	–	£0.00	£0.00
	Alternator 14 V / 200 A	M40	-	●	£0.00	£0.00
	Alternator 14 V / 230 A	M48	○	–	£485.00	£582.00
	Alternator 14 V / 250 A	M60	–	○	£485.00	£582.00
	Alternator 14 V / 280 A	M61	–	○	£790.00	£948.00
<b>Audio Entertainment</b>	Navigation Includes: 3 years of free map updates (EX9), Digital Owner's Manual (XO5) and Live Traffic capability (E1G).	E1E	○	○	£725.00	£870.00
	Communication module (LTE) for digital services Transfers data particularly rapidly and reliably with its permanently installed SIM card, creating the technical conditions for using the Mercedes me connect services.	JH3	●	●	£0.00	£0.00

● Standard ○ Optional – Not available

The Mercedes-Benz Sprinter

13

# Equipment (standard and optional overview).



RETURN TO START

Equipment	Description	Option code	Front-wheel drive	Rear-wheel drive	Basic Price excl. VAT	Basic Price incl. VAT
			PROGRESSIVE	PROGRESSIVE		
<b>Technology Software and Electrics (cont.)</b>						
Audio Entertainment (cont.)	<b>Digital Radio (DAB)</b>	E1D	●	●	£0.00	£0.00
	<b>MBUX multimedia system with 7-inch touch screen</b> The MBUX multimedia system with 17.8 cm (7-inch) touchscreen boasts intuitive touchscreen operation, a high-resolution touchscreen and a wealth of communication and infotainment features.	E3M	●	●	£0.00	£0.00
	<b>MBUX multimedia system with 10.25-inch touch screen</b> Features of the MBUX multimedia system with high-resolution 26 cm (10.25-inch) touchscreen include fast hard-disc navigation with 3-D map display and smartphone integration.	E4M	○	○	£1,900.00	£2,280.00
Battery	<b>AGM battery, 12 V 70 Ah</b>	ED1	○	○	£0.00	£0.00
	<b>Auxiliary battery retrofit consumers vehicle interior</b> Includes: Cut-off relay for auxiliary battery (E36).	E2I	○	○	£345.00	£414.00
	<b>Battery master switch, single-pin</b>	E30	○	○	£110.00	£132.00
	<b>Cut-off relay for auxiliary battery</b>	E36	○	○	£100.00	£120.00
	<b>Engine run-on system</b> (Only for blue light and armed services).	MW1	○	○	£850.00	£1,020.00
	<b>Heavy-duty battery (12v 92 aH)</b>	ED4	●	●	£0.00	£0.00
	<b>Jump start contact</b>	ES0	●	●	£0.00	£0.00
Electronics	<b>Charging package, dashboard (Two 5v USB-C sockets and 12v socket)</b>	ES5	○	○	£65.00	£78.00
	<b>Extension of Programmable System Module (PSM) standard contact</b> (Additional connection options for body manufacturers).	E5M	○	○	£60.00	£72.00
	<b>Parameterizable special module</b>	ED5	○	○	£300.00	£360.00
	<b>Plug socket in cab</b>	E46	○	○	£45.00	£54.00
	<b>Pre-wiring for parameterizable special module (PSM)</b>	ED8	●	●	£0.00	£0.00
	<b>Terminal strip for electrical connection</b>	EK1	●	●	£0.00	£0.00
	<b>USB-C socket, 5 V</b>	E1U	●	●	£0.00	£0.00
Keys	<b>2 additional master keys</b>	FZ9	○	○	£115.00	£138.00
	<b>Multi-button key</b>	FY7	○	○	£30.00	£36.00

● Standard ○ Optional — Not available

# Equipment (standard and optional overview).



RETURN TO START

Equipment	Description	Option code	Front-wheel drive	Rear-wheel drive	Basic Price excl. VAT	Basic Price incl. VAT
			PROGRESSIVE	PROGRESSIVE		
<b>Technology Software and Electrics (cont.)</b>						
Tachograph	<b>EU Intelligent Tachograph Std over 3.5T</b> Note: Standard on 5 series Sprinter Chassis	JD6	○	○	£770.00	£924.00
	<b>Omission tachograph</b> Includes: Linear speed limiter 90 km/h EG (MD4), Qualification N2 (Z2N), Weight variant 3,550 kg (XG4) and Lane Keeping ASSIST (JW5).	J92	○	○	£0.00	£0.00
	<b>Tachograph control under dashboard, co-driver side</b>	J2B	○	○	£0.00	£0.00
<b>Driver's Assistance and Safety Equipment</b>						
Airbags	<b>Airbag driver seat</b>	SA5	●	●	£0.00	£0.00
	<b>Airbag co-drivers seat</b> Includes: Seatbelt reminder for co-drivers seat.	SA6	○	○	£335.00	£402.00
	<b>Thorax/pelvis/side airbag for driver</b> Includes: Front airbag co-driver (SA6) and Seat belt reminder (J55).	SH1	○	○	£680.00	£816.00
	<b>Thorax/pelvis/side airbag for co-driver</b> Includes: Thorax/pelvis/side airbag for driver (SH1), Front airbag co-driver (SA6) and Seat belt reminder (J55).	SH2	○	○	£925.00	£1,110.00
	<b>Window airbags for driver and co-driver</b>	SH9	○	○	£600.00	£720.00
Brake	<b>Active Brake ASSIST</b> Active Brake ASSIST can help to prevent accidents with vehicles ahead and crossing pedestrians or to mitigate their consequences.	BA3	●	●	£0.00	£0.00
	<b>Adaptive brake light</b>	LE1	●	●	£0.00	£0.00
	<b>Electrical parking brake</b>	B25	○	○	£285.00	£342.00
	<b>Folding handbrake lever</b>	BE2	○	○	£55.00	£66.00
	<b>Hill-Start ASSIST</b> Hill-Start ASSIST works by sensing the van is on an incline and holding the brakes for a few seconds – even after the handbrake has been released – until the clutch's biting point has been found and the van begins to move forwards.	E07	●	●	£0.00	£0.00
	<b>HOLD function</b> (Braking assistance on downhill stretches and at a traffic light stop). Only in conjunction with: G42 or GK8.	BH1	○	○	£0.00	£0.00
	<b>Wheel chock</b> Note: Standard on over 3.5t	Y26	○	○	£45.00	£54.00

● Standard ○ Optional – Not available

# Equipment (standard and optional overview).



RETURN TO START

Equipment	Description	Option code	Front-wheel drive	Rear-wheel drive	Basic Price excl. VAT	Basic Price incl. VAT
			PROGRESSIVE	PROGRESSIVE		
<b>Driver's Assistance and Safety Equipment (cont.)</b>						
<b>Driver's Assistance</b>	<b>Active Distance ASSIST DISTRONIC</b> Includes: Leather steering wheel (CL3), Instrument cluster with colour display (JK5), 9G-TRONIC PLUS (G43) and HOLD function (BH1).	ET4	○	○	£3,220.00	£3,864.00
	<b>Active Lane Keeping ASSIST</b> Active Lane Keeping ASSIST can help to detect when the vehicle is unintentionally departing its lane, warn the driver and, if necessary, actively help to return the vehicle to its lane by means of braking interventions.	JB4	○	○	£430.00	£516.00
	<b>ATTENTION ASSIST</b> The ATTENTION ASSIST drowsiness detection system can recognise early signs of fatigue on long routes and night-time drives, and prompt the driver to take a break from driving.	JW8	●	●	£0.00	£0.00
	<b>Comfort overhead control panel</b> LED interior lighting including cab downlighting and co-/driver reading lamps; also includes a convenient spectacles compartment.	LC4	●	●	£0.00	£0.00
	<b>Crosswind ASSIST</b> Crosswind ASSIST detects track offset caused by strong crosswind gusts in due time and helps the driver to stay in lane.	JA8	●	●	£0.00	£0.00
	<b>Cruise control</b> Includes speed limiter function. Operated via a lever ergonomically positioned on the left of the steering column.	MS1	●	●	£0.00	£0.00
	<b>Fire extinguisher</b>	Y16	○	○	£110.00	£132.00
	<b>First aid kit</b>	Y10	○	○	£0.00	£0.00
	<b>Lane Keeping ASSIST</b> Lane Keeping ASSIST can help prevent accidents caused by unintentional lane departures with visual, audible and tactile signals.	JW5	○	○	Please speak to your Dealer	
	<b>Provision electrics for reversing aid</b>	FR7	○	○	£100.00	£120.00
	<b>Rain sensor</b> The rain sensor automatically regulates the wiping frequency of the windscreen wipers with activated intermittent wiping, which makes things easier for the driver.	JF1	○	○	£110.00	£132.00
	<b>Reversing warning device includes Switch-off (JW3)</b>	JW0	○	○	£220.00	£264.00
	<b>Traffic Sign ASSIST</b> Includes: 3 years of free map updates (EX9), Digital Owner's Manual (XO5), Instrument cluster with colour display (JK5), Navigation (E1E) and Live Traffic capability (E1G).	JA9	○	○	£1,165.00	£1,398.00
	<b>Warning triangle</b>	Y44	○	○	£0.00	£0.00

● Standard ○ Optional — Not available



# Equipment (standard and optional overview).



RETURN TO START

Equipment	Description	Option code	Front-wheel drive	Rear-wheel drive	Basic Price excl. VAT	Basic Price incl. VAT
			PROGRESSIVE	PROGRESSIVE		
<b>Driver's Assistance and Safety Equipment (cont.)</b>						
Driver's Assistance (cont.)	<b>WET WIPER system.</b> The WET WIPER SYSTEM windscreen wiper system offers the driver an improved view already during the wiping process. Includes: Rain sensor (JF1).	FM3	○	○	£110.00	£132.00
Road speed limiters	<b>Linear speed limiter 90 km/h</b>	MD5	○	○	£70.00	£84.00
	<b>Linear speed limiter 100 km/h</b>	MD3	○	○	£70.00	£84.00
	<b>Linear speed limiter 120 km/h</b>	MD4	○	○	£70.00	£84.00
	<b>Speed limiter, 110 km/h</b>	MK0	○	○	£140.00	£168.00
	<b>Speed limiter, 130 km/h</b>	MK2	○	○	£140.00	£168.00
Safety	<b>Breakdown management</b>	EY6	●	●	£0.00	£0.00
	<b>Clearance light on roof</b>	LB8	○	○	£305.00	£366.00
	<b>ECO start/stop function</b> Note: Not available in conjunction with AWD or 314 RWD Chassis Includes: Alternator 14 V/200 A (M40) on RWD.	MJ8	●	●	No-cost option	No-cost option
	<b>Deactivation of bulb failure indicator</b>	JW2	○	○	£0.00	£0.00
	<b>Live Traffic capability</b> Note: Only available in conjunction with navigation.	E1G	○	○	£0.00	£0.00
	<b>Incorrect fuelling protection system</b>	K51	○	○	£50.00	£60.00
	<b>Mercedes-Benz emergency call system</b>	EY5	●	●	£0.00	£0.00
	<b>Outside temperature indicator</b>	J65	●	●	£0.00	£0.00
	<b>Seat belt reminder for co-driver seat</b>	J55	○	○	£100.00	£120.00
<b>Seat belt warning for driver's seat</b>	J58	●	●	£0.00	£0.00	
Security	<b>Anti-theft Alarm</b> Alarm protection for vehicle and cargo.	FY1	●	●	£0.00	£0.00
	<b>Double locks</b>	FY2	●	●	£0.00	£0.00
	<b>VIN visible from outside</b>	XC8	●	●	£0.00	£0.00
<b>Lighting</b>						
Lighting	<b>Courtesy lights</b> The exit lights at the front doors and sliding doors improve comfort and safety when getting in and out - both for driver and co-driver as well as for the passengers in the passenger compartment.	LB9	○	○	£70.00	£84.00
	<b>Direction indicators on the front wings</b> Includes: Exterior mirrors without indicators (FU5).	L44	○	○	£100.00	£120.00

● Standard ○ Optional — Not available

# Equipment (standard and optional overview).



RETURN TO START

Equipment	Description	Option code	Front-wheel drive	Rear-wheel drive	Basic Price excl. VAT	Basic Price incl. VAT
			PROGRESSIVE	PROGRESSIVE		
<b>Lighting (cont.)</b>						
Lighting (cont.)	<b>Fog lamps with cornering light function</b>	L13	○	○	£210.00	£252.00
	<b>Headlight assistant</b> The automatic headlamps automatically switch the dipped beams on and off depending on the current light conditions, which increases the driving comfort for the driver, and the road safety.	LA2	●	●	£0.00	£0.00
	<b>Highbeam ASSIST</b> Highbeam ASSIST automatically switches the main beams on and off in line with the traffic situation and thereby relieves the driver of manually switching back and forth between main beams and dipped beams.	LA1	○	○	£280.00	£336.00
	<b>LED high performance headlamps</b> Includes: Tail lamps with partial LED technology (L22).	LG7	○	○	£1,545.00	£1,854.00
	<b>Lights for left hand traffic</b>	L10	●	●	£0.00	£0.00
	<b>Preparation for side marker lights</b>	LB2	–	–	£0.00	£0.00
	<b>Omission parking lamp</b>	L94	○	○	£0.00	£0.00
	<b>Side marker lights</b> Note: Standard on L2 upwards.	LB1	–	●	£0.00	£0.00
	<b>Tail light wiring harness, extended</b>	L76	–	–	£75.00	£90.00
<b>Loading and Towing</b>						
<b>Gross Vehicle Weight (GVW)</b>	<b>Weight variant 3,550 kg</b> XG4 is available as a uprated payload variant for vehicles of the weight class 3,500 kg with front or rear-wheel drive.	XG4	○	○	£355.00	£426.00
<b>Load Area</b>	<b>Omission wooden floor</b>	V010	○	○	£0.00	£0.00
<b>Towing Equipment</b>	<b>Crossmember for trailer coupling</b>	Q10	○	○	£240.00	£288.00
	<b>Electrical components for trailer socket</b>	E57	○	○	£110.00	£132.00
	<b>Pre-installation for vehicle towing capacity up to 2,800 kg</b> Includes: Electrical components for trailer socket (E57). Axle ratio i = 4,182 (AR3).	QA5	–	○	£165.00	£198.00
	<b>Pre-installation for vehicle towing capacity up to 3,500 kg</b> Includes: Electrical components for trailer socket (E57). Axle ratio i = 4,727 (AR5).	QA3	–	○	£315.00	£378.00
	<b>Removable tow ball trailer coupling</b>	Q50	○	○	£400.00	£480.00
	<b>Towing eye rear</b>	Q67	○	○	£15.00	£18.00
	<b>Trailer coupling for increased towing capacity 2.8 t/3.0 t</b> Includes: Electrical components for trailer socket (E57). Axle ratio i = 4,182 (AR3).	QA8	–	○	£590.00	£708.00

● Standard ○ Optional – Not available

# Equipment (standard and optional overview).



RETURN TO START

Equipment	Description	Option code	Front-wheel drive	Rear-wheel drive	Basic Price excl. VAT	Basic Price incl. VAT
			PROGRESSIVE	PROGRESSIVE		
<b>Loading and Towing (cont.)</b>						
Towing Equipment (cont.)	<b>Trailer coupling for increased towing capacity of 3.5 t</b> Includes: Electrical components for trailer socket (E57). Axle ratio i = 4,727 (AR5) + 9G-TRONIC PLUS (G43).	QA7	—	○	£670.00	£804.00
	<b>Trailer coupling with fixed tow ball</b>	Q22	○	○	£350.00	£420.00
	<b>Trailer coupling with mouth 243 / U115</b>	Q20	—	○	£515.00	£618.00
	<b>Trailer socket, 13-pin</b>	E43	○	○	£150.00	£180.00
<b>Mirrors and Windows</b>						
<b>Mirrors</b>	<b>Electrically foldable exterior mirrors</b> Includes: Side mirrors, heated and power-adjustable (F68).	F64	○	○	£230.00	£276.00
	<b>Exterior mirrors without indicators</b> Includes: Direction indicators on the side at the front (L44).	FU5	○	○	£100.00	£120.00
	<b>Heated and power-adjustable side mirrors</b>	F68	○	○	£180.00	£216.00
	<b>Omission of extended mirror bracket</b>	FA70	—	—	£0.00	£0.00
	<b>Rear-view mirror</b>	F61	○	○	£0.00	£0.00
<b>Windows</b>	<b>Omission of window in cab rear wall</b>	FB00	○	○	£0.00	£0.00
	<b>Heat-insulating glass all round</b>	H20	○	○	£140.00	£168.00
	<b>Heat-insulating glass with filter band on windscreen</b>	H21	●	●	£0.00	£0.00
	<b>Windscreen, heated</b> Includes: Air conditioning, semi-automatically controlled, TEMPATIC (HH9).	F49	○	○	£1,395.00	£1,674.00

● Standard ○ Optional — Not available

# Engine and gearbox.



RETURN TO START

	Euro 6d		Euro VI		
	x15	x17	x15	x17	x19
<b>Fuel</b>	Diesel		Diesel		
<b>Mixture preparation/injection method</b>	Common-rail direct injection with twin stage turbocharging		Common-rail direct injection with twin stage turbocharging		
<b>Cylinder arrangement</b>	4cyl 16v		4cyl 16v		
<b>Cubic capacity</b>	1,950cc		1,950cc		
<b>EU exhaust emission standard</b>	Euro 6d		Euro VI		
<b>Output, max. at 3,800rpm</b>	150hp	170hp	150hp	170hp	190hp
<b>Torque, max.</b>	max. 340 Nm at 1,500 – 2,400 rpm	max. 400 Nm at 1,700 – 2,400 rpm	max. 340 Nm at 1,500 – 2,400 rpm	max. 400 Nm at 1,700 – 2,400 rpm	max. 450 Nm at 1,400 to 2,400 rpm
<b>Fuel tank capacity FWD</b>	65 litres		65 litres		
<b>Fuel tank capacity RWD</b>	71 litres		71 litres		
<b>Fuel tank capacity AWD</b>	–		–	–	93 litres
<b>AbBlue® capacity</b>	22 litres		22 litres		
<b>6-speed manual transmission</b>	●	●	●	●	●
<b>9G-TRONIC</b>	○	○	○	○	○
<b>FWD</b>	●	–	●	–	–
<b>RWD</b>	●	●	●	●	●
<b>AWD</b>	–	–	–	–	●
<b>Alternator</b>	14 V/180 A		14 V/180 A		
<b>Battery</b>	Heavy-duty battery (12v 92 aH)		Heavy-duty battery (12v 92 aH)		

● Standard ○ Optional – Not available

# Fuel consumption, performance and CO<sub>2</sub> emissions.



RETURN TO START

Euro 6d					
Model	WLTP Fuel Consumption (l/100km/MPG)				
	Combined	Low-Speed	Medium-Speed	High-Speed	Extra High-Speed
<b>Chassis Cab - PROGRESSIVE</b>					
315 Chassis L2 RWD	10.9/ <b>25.92</b>	11.1/ <b>25.4</b>	8.9/ <b>31.7</b>	9.1/ <b>31</b>	13.6/ <b>20.7</b>
315 Chassis L3 RWD	9/ <b>31.39</b>	9.8/ <b>28.8</b>	7.4/ <b>38.1</b>	7.5/ <b>37.6</b>	11.2/ <b>5.2</b>
315 Chassis L2 FWD	11.1/ <b>25.4</b>	11.1/ <b>25.4</b>	9.2/ <b>30.7</b>	9.3/ <b>30.3</b>	14/ <b>20.1</b>
317 Chassis L2 RWD	9/ <b>31.39</b>	9.5/ <b>29.7</b>	7.5/ <b>37.6</b>	7.5/ <b>37.6</b>	11.2/ <b>25.2</b>
317 Chassis L3 RWD	9/ <b>31.39</b>	9.6/ <b>29.4</b>	7.5/ <b>37.6</b>	7.6/ <b>37.1</b>	11.2/ <b>25.2</b>
<b>Chassis Crewcab - PROGRESSIVE</b>					
315 Crewcab L3 RWD	9.3/ <b>30.3</b>	10.1/ <b>27.9</b>	7.7/ <b>36.6</b>	7.8/ <b>36.2</b>	11.4/ <b>24.78</b>

Euro VI					
Model	WLTP Fuel Consumption (l/100km/MPG)				
	Combined	Low-Speed	Medium-Speed	High-Speed	Extra High-Speed
<b>Chassis Cab - PROGRESSIVE</b>					
315 Chassis L2 RWD	12.6/ <b>22.4</b>	11.2/ <b>25.2</b>	9.9/ <b>28.53</b>	10.9/ <b>25.9</b>	16/ <b>17.6</b>
315 Chassis L3 RWD	12.6/ <b>22.4</b>	11.2/ <b>25.2</b>	9.9/ <b>28.53</b>	10.9/ <b>25.9</b>	16/ <b>17.6</b>
317 Chassis L2 RWD	13.1/ <b>21.5</b>	11.4/ <b>24.7</b>	10.1/ <b>27.9</b>	11.2/ <b>25.2</b>	17/ <b>16.6</b>
317 Chassis L3 RWD	13.1/ <b>21.5</b>	11.4/ <b>24.7</b>	10.1/ <b>27.9</b>	11.2/ <b>25.2</b>	17/ <b>16.6</b>
515 Chassis L2 RWD	13.9/ <b>20.3</b>	13.4/ <b>21</b>	11.7/ <b>24.1</b>	12.5/ <b>22.6</b>	16.5/ <b>17.1</b>
515 Chassis L3 RWD	13.9/ <b>20.3</b>	13.4/ <b>21</b>	11.7/ <b>24.1</b>	12.5/ <b>22.6</b>	16.5/ <b>17.1</b>
517 Chassis L2 RWD*	TBA				
517 Chassis L3 RWD*					
519 Chassis L2 AWD*					
519 Chassis L2 RWD	15.6/ <b>18.1</b>	14.4/ <b>19.62</b>	12.5/ <b>22.6</b>	13.5/ <b>20.9</b>	19.8/ <b>14.2</b>
519 Chassis L3 RWD	15.6/ <b>18.1</b>	14.4/ <b>19.62</b>	12.5/ <b>22.6</b>	13.5/ <b>20.9</b>	19.8/ <b>14.2</b>
<b>Chassis Crewcab - PROGRESSIVE</b>					
315 Crewcab L3 RWD	12.6/ <b>22.4</b>	11.2/ <b>25.2</b>	9.9/ <b>28.53</b>	10.9/ <b>25.9</b>	16/ <b>17.6</b>
515 Crewcab L3 RWD	13.9/ <b>20.3</b>	13.4/ <b>21</b>	11.7/ <b>24.1</b>	12.5/ <b>22.6</b>	16.5/ <b>17.1</b>

\* Model to be released 2022.

All figures are based on a standard specification. The addition of factory options may affect CO<sub>2</sub> emissions and corresponding Road Fund Licence. The indicated values were determined according to the prescribed measurement method – Worldwide Harmonised Light Vehicle Test Procedure (WLTP). Figures shown may include options which are not available in the UK. Figures shown are for comparability purposes; only compare with other vans tested to the same technical procedures. Figures may not reflect real life driving results, which will depend upon a number of factors including Body fitted, factory-fitted options, accessories fitted (post registration), variations in weather, driving styles and vehicle load. Further information about the test used to establish fuel consumption and CO<sub>2</sub> figures can be found at <https://www.Mercedes-Benz.co.uk/vans/en/WLTP>

# Fuel consumption, performance and CO<sub>2</sub> emissions.



RETURN TO START

Euro 6d					
Model	WLTP CO <sub>2</sub> emissions (g/km)				
	Combined	Low-Speed	Medium-Speed	High-Speed	Extra High-Speed
<b>Chassis Cab - PROGRESSIVE</b>					
315 Chassis L2 RWD	285	292	234	239	358
315 Chassis L3 RWD	237	257	195	198	294
315 Chassis L2 FWD	291	291	242	243	367
317 Chassis L2 RWD	236	249	195	197	293
317 Chassis L3 RWD	237	251	197	198	293
<b>Chassis Crewcab - PROGRESSIVE</b>					
315 Crewcab L3 RWD	243	265	202	204	300

Euro VI					
Model	WLTP CO <sub>2</sub> emissions (g/km)				
	Combined	Low-Speed	Medium-Speed	High-Speed	Extra High-Speed
<b>Chassis Cab - PROGRESSIVE</b>					
315 Chassis L2 RWD	330	293	259	288	421
315 Chassis L3 RWD	330	293	259	288	421
317 Chassis L2 RWD	343	300	266	293	447
317 Chassis L3 RWD	343	300	266	293	447
515 Chassis L2 RWD	364	352	306	328	433
515 Chassis L3 RWD	364	352	306	328	433
517 Chassis L2 RWD*	TBA				
517 Chassis L3 RWD*					
519 Chassis L2 AWD*					
519 Chassis L2 RWD	410	376	328	354	518
519 Chassis L3 RWD	410	376	328	354	518
<b>Chassis Crewcab - PROGRESSIVE</b>					
315 Crewcab L3 RWD	330	293	259	288	421
515 Crewcab L3 RWD	364	352	306	328	433

\* Model to be released 2022.

All figures are based on a standard specification. The addition of factory options may affect CO<sub>2</sub> emissions and corresponding Road Fund Licence. The indicated values were determined according to the prescribed measurement method – Worldwide Harmonised Light Vehicle Test Procedure (WLTP). Figures shown may include options which are not available in the UK. Figures shown are for comparability purposes; only compare with other vans tested to the same technical procedures. Figures may not reflect real life driving results, which will depend upon a number of factors including Body fitted, factory-fitted options, accessories fitted (post registration), variations in weather, driving styles and vehicle load. Further information about the test used to establish fuel consumption and CO<sub>2</sub> figures can be found at <https://www.Mercedes-Benz.co.uk/vans/en/WLTP>

# Weights and payloads.



RETURN TO START

Euro 6d				
Model	Kerb weight (kg)	Gross Vehicle Weight (kg)	Payload (kg)	Gross Train Weight (kg)
<b>Chassis Cab - PROGRESSIVE</b>				
315 Chassis L2 RWD	1,860	3,500	1,640	5,500
315 Chassis L3 RWD	1,893	3,500	1,607	5,500
315 Chassis L2 FWD	1,806	3,500	1,694	5,500
317 Chassis L2 RWD	1,881	3,500	1,619	5,500
317 Chassis L3 RWD	1,914	3,500	1,586	5,500
<b>Chassis Crewcab - PROGRESSIVE</b>				
315 Crewcab L3 RWD	2,062	3,500	1,438	5,500

Euro VI				
Model	Kerb weight (kg)	Gross Vehicle Weight (kg)	Payload (kg)	Gross Train Weight (kg)
<b>Chassis Cab - PROGRESSIVE</b>				
315 Chassis L2 RWD	1,881	3,500	1,619	5,500
315 Chassis L3 RWD	1,914	3,500	1,586	5,500
317 Chassis L2 RWD	1,881	3,500	1,619	5,500
317 Chassis L3 RWD	1,914	3,500	1,586	5,500
515 Chassis L2 RWD	2,075	4,250	2,175	6,250
515 Chassis L3 RWD	2,115	4,250	2,135	6,250
517 Chassis L2 RWD*	TBA			
517 Chassis L3 RWD*				
519 Chassis L2 AWD*				
519 Chassis L2 RWD	2,088	4,250	2,162	6,250
519 Chassis L3 RWD	2,128	4,250	2,122	6,250
<b>Chassis Crewcab - PROGRESSIVE</b>				
315 Crewcab L3 RWD	2,083	3,500	1,417	5,500
515 Crewcab L3 RWD	2,299	4,250	1,951	6,250

\* Model to be released 2022.

# Dimensions.



RETURN TO START

## CHASSIS CAB FRONT-WHEEL DRIVE L2

Wheelbase	Wheelbase length	3,924mm
	Turning circle	15.2m
	Track circle	14.4m
	Front track width	1,759mm
	Rear track width	1,770mm
Vehicle	Length	5,986mm
	Height (unladen)	2,292mm
	Width (inc. wing mirrors)	2,345mm
	Ground clearance	143mm

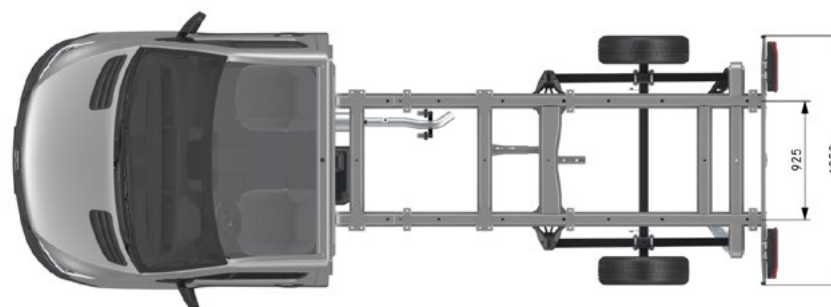
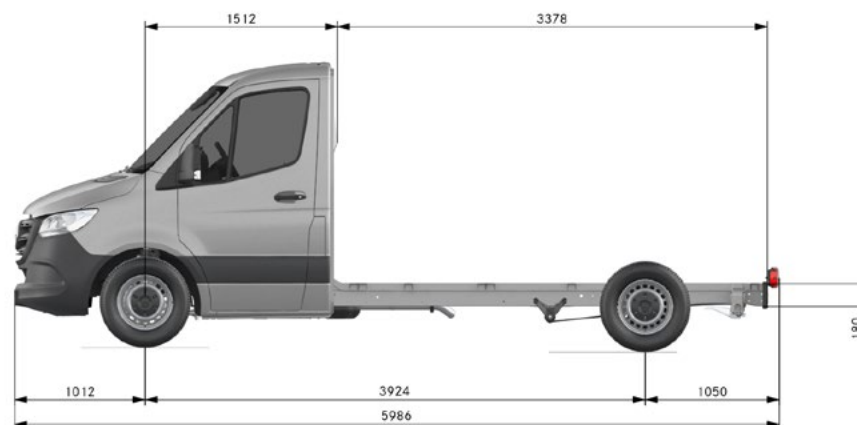



# Dimensions.



RETURN TO START

## CHASSIS CAB REAR-WHEEL DRIVE **L2**

Wheelbase	Wheelbase length	3,665mm
	Turning circle	13.3m
	Track circle	12.4m
	Front track width	1,726mm
	Rear track width	1,732mm
Vehicle	Length	5,886mm
	Height (unladen)	2,318mm
	Width (inc. wing mirrors)	2,345mm
	Ground clearance	188mm

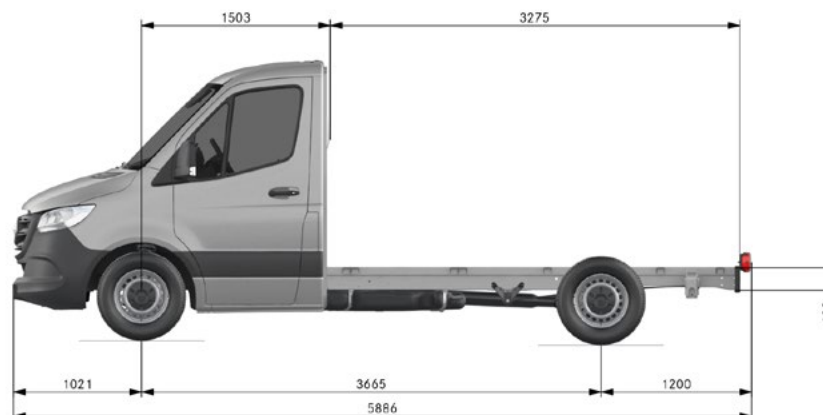

# Dimensions.



RETURN TO START

## CHASSIS CAB REAR-WHEEL DRIVE L3

Wheelbase	Wheelbase length	4,325mm
	Turning circle	15.3m
	Track circle	14.4m
	Front track width	1,726mm
	Rear track width	1,732mm
Vehicle	Length	6,695mm
	Height (unladen)	2,311mm
	Width (inc. wing mirrors)	2,345mm
	Ground clearance	188mm

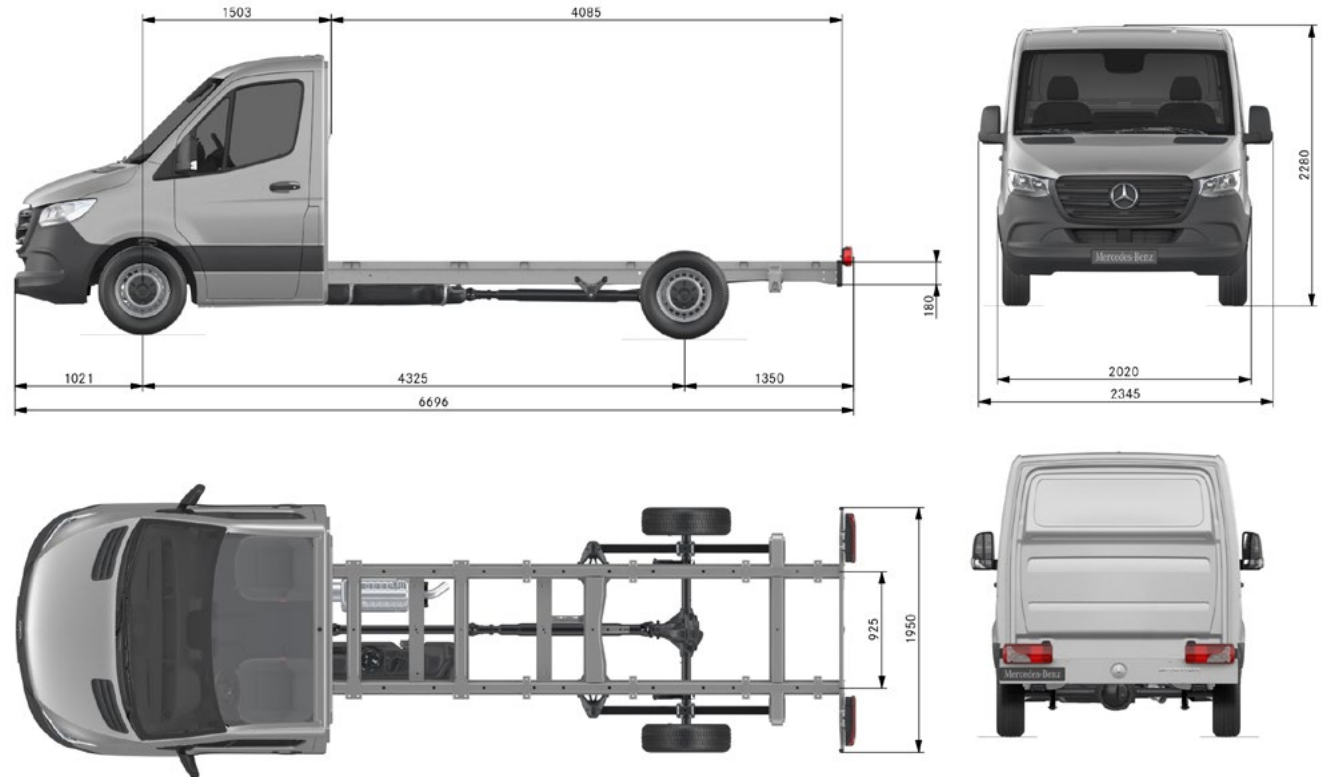

# Dimensions.



RETURN TO START

## CHASSIS CREWCAB REAR-WHEEL DRIVE L3

Wheelbase	Wheelbase length	4,325mm
	Turning circle	15.3m
	Track circle	14.4m
	Front track width	1,726mm
	Rear track width	1,732mm
Vehicle	Length	6,695mm
	Height (unladen)	2,301mm
	Width (inc. wing mirrors)	2,345mm
	Ground clearance	188mm

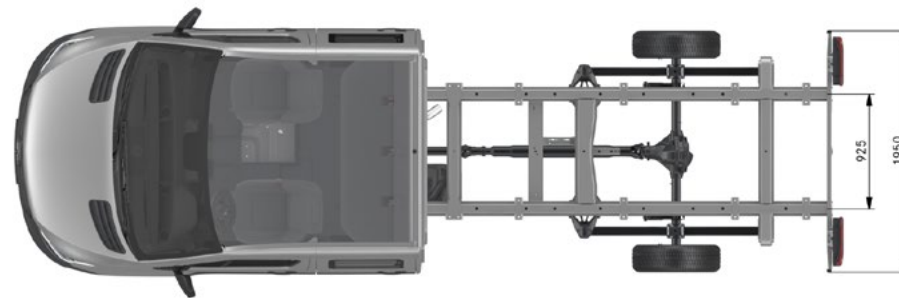
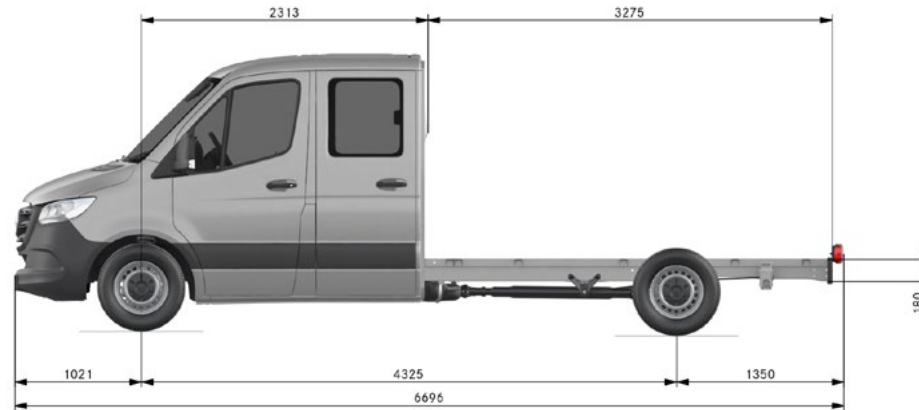

# List prices.



RETURN TO START

Euro 6d		
Model	Basic Recommended Retail Price (Ex. VAT)	Basic Recommended Retail Price (Inc. VAT)
<b>Chassis Cab - PROGRESSIVE</b>		
315 Chassis L2 RWD	£39,610	£47,532
315 Chassis L3 RWD	£40,490	£48,588
315 Chassis L2 FWD	£38,185	£45,822
317 Chassis L2 RWD	£40,610	£48,732
317 Chassis L3 RWD	£41,480	£49,776
<b>Chassis Crewcab - PROGRESSIVE</b>		
315 Crewcab L3 RWD	£43,780	£52,536

Euro VI		
Model	Basic Recommended Retail Price (Ex. VAT)	Basic Recommended Retail Price (Inc. VAT)
<b>Chassis Cab - PROGRESSIVE</b>		
315 Chassis L2 RWD	£39,605	£47,532
315 Chassis L3 RWD	£40,490	£48,588
317 Chassis L2 RWD	£40,610	£48,732
317 Chassis L3 RWD	£41,480	£49,776
515 Chassis L2 RWD	£47,760	£57,312
515 Chassis L3 RWD	£48,640	£58,368
517 Chassis L2 RWD*	£48,535	£58,242
517 Chassis L3 RWD*	£49,415	£59,298
519 Chassis L2 AWD*	£57,360	£68,832
519 Chassis L2 RWD	£51,730	£62,076
519 Chassis L3 RWD	£52,610	£63,132
<b>Chassis Crewcab - PROGRESSIVE</b>		
315 Crewcab L3 RWD	£43,780	£52,536
515 Crewcab L3 RWD	£51,720	£62,064

- › All prices based on manual transmission. Automatic transmissions available as an option – [see page 11](#)
- › For special orders please consult your local Dealer – [find your nearest Dealership](#)

\* Model to be released 2022.

This document is for guidance only and must be used in conjunction with a configuration tool prior to final specification decisions and vehicle quotations being prepared and accepted. List prices are quoted ex-factory unless otherwise stated. Delivery charges excluding VAT will be added to model prices quoted in this document. Prices based on standard finish paint choice. Mercedes-Benz Vans UK and authorised Dealers reserve the right to alter specification and vary prices without notice. The availability of options may depend on the chosen base vehicle and other optional equipment specified, and should be confirmed with your Mercedes-Benz Vans Dealer prior to order placement. VAT is calculated at the standard rate of 20%. Mercedes-Benz Vans UK Ltd, Tongwell, Milton Keynes MK15 8BA.

# Mercedes-Benz Approved Used vans.

## Get used to more...

### More choice. More confidence. More quality – and more added extras.

As a Mercedes-Benz Approved Used customer, you'll have complete peace of mind as every van offers the same commitment to quality and workmanship as new and comes with:



Minimum 12-month warranty\*  
PLUS the option of monthly top-ups, up to 24 months\*



Free MOT test failure cover\*\*  
covering you for £1,500

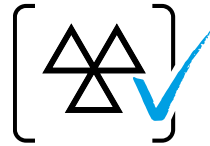

Minimum  
3 months MOT

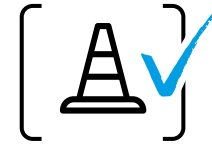

Free 24/7 breakdown cover  
and roadside assistance^



Free 7-day driveway  
van insurance^^



Comprehensive  
multi-point vehicle check

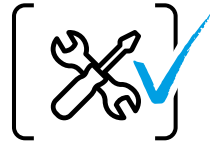

Discounted  
service plans

### ▶ [View our Dealer Networks Approved Used van stock](#)

\*Warranty eligible up to 200,000 miles on approved used Mercedes-Benz Vans with less than 150,000 miles at point of sale. Top ups are to a maximum of 24 months. For full T&Cs, please speak to your preferred sales representative. \*\* MOT cover redeemable per 12-months warranty. £1,500 claims limit. For more information, please speak to your preferred sales representative. ^ Free for 12 months initially and renewed at each service, if serviced by MB according to service intervals for up to 30 years from when the vehicle was first registered. For a full list of exclusions and all product terms please visit [mbvans.co.uk/mobilovan](http://mbvans.co.uk/mobilovan) ^^ Available on single vehicle policies only and applicable on Vehicles up to 3.5t only. For full terms and conditions, please consult your local Dealer. Mercedes-Benz Van Insurance is a trading name of Mercedes-Benz Insurance Services UK Limited. Prices are correct at time of going to press 07/2021. All prices are subject to any fiscal or legislative changes.



Approved  
Used



## What is an Approved Used van?

- Is no older than 6 years old
- Is eligible for one of our flexible finance plans
- Has less than 150,000 miles on the clock

▶ [Find more information and our latest Approved Used offers](#)

## Ready to go electric?

▶ [Find our latest Approved Used Electric offers](#)

The Mercedes-Benz Sprinter

29



RETURN TO START

# Finance options.

## Get an agreement that suits you with Mercedes-Benz Finance.

At Mercedes-Benz Finance we understand what it takes to run a modern-day business. Because of this, we have a number of finance options ready to suit your business needs.

### Agility

A flexible way of financing a vehicle over a fixed term. At the start of your agreement, decide on your deposit amount, expected annual mileage and how long you want the agreement to last.

- You'll have fixed regular payments meaning you can easily budget
- Payments are only based on a part of the vehicle's value, keeping your payments lower
- You're in control: At the end of the agreement you can decide to purchase your vehicle, return it, or part-exchange it for a new one.

### Hire Purchase

A great choice if you want to own the vehicle outright. At the start of your agreement, decide on your deposit amount and how long you want the agreement to last, and we'll work out your monthly payments.

- The monthly payments are not based on annual mileage
- You have the option to have a balloon payment at the end of the agreement, which will lower your monthly payments
- When you've paid all the monthly repayments and Purchase Activation Fee, the vehicle is yours to keep.

### Operating Lease

For those who want to drive a Mercedes-Benz over a fixed term, without the commitment of taking full ownership. Decide on your advance rental amount, expected annual mileage, and how long you want the agreement to last.

- Once all rentals are paid, you simply hand your vehicle back
- You only repay part of the vehicle's value, keeping your monthly rentals lower
- For business customers, rentals are allowable against taxable profits (proportionally).

### Contract Hire

Gives you the ability to enjoy driving a Mercedes-Benz without taking on full ownership. Decide on your advance rental amount, expected annual mileage how long you want the agreement to last, and any servicing options.

- The monthly rentals include the cost of the Vehicle Excise Duty
- You only repay part of the vehicle's value, keeping your monthly rentals lower
- For business users, VAT is reclaimable depending on your usage (proportionally).

### Finance Lease

Hire the vehicle for a fixed period without the option of ownership. Pay an agreed amount upfront, and decide if you wish to include a balloon payment at the end of your agreement. This lowers your monthly rentals.

- The fixed regular rentals enable you to easily budget, and are not based on annual mileage
- The vehicle is an asset on the balance sheet, therefore tax allowances may be deducted from taxable profits
- At the end of your agreement, there is an option to extend for an agreed period by paying a 'peppercorn' payment. This is equal to one month's rental per annum.

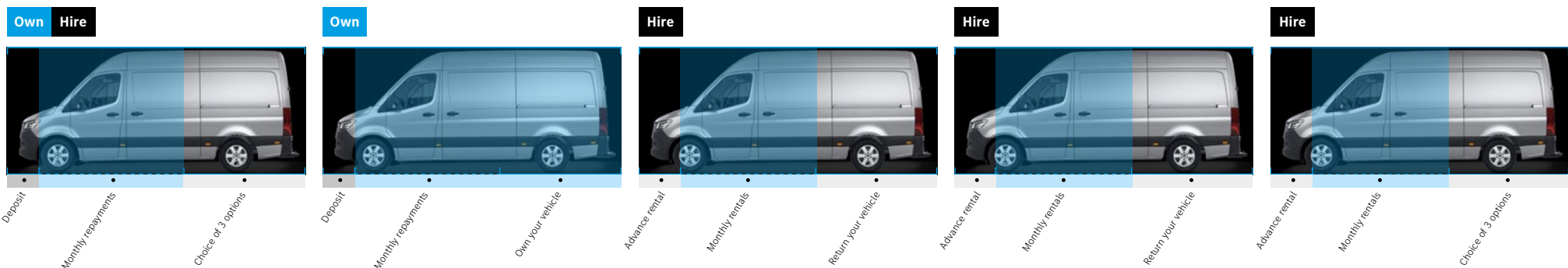

► [For more information about our finance options](#)

# Service24: Demand more

## The most comprehensive Aftercare package – for businesses that demand more.

Our 120-strong Dealer network works around the clock to service and maintain your vans and keep your business moving. It all adds up to more value, more flexibility and more confidence that you'll only find at an authorised Mercedes-Benz Dealer.



### › Flexible servicing and maintenance

Book your service online or by telephone, and as well as a standard 'drop and go' service with a courtesy van, you'll also get:

- Early bird, late night and weekend slots
- Mobile service
- Overnight service
- Collect & deliver service
- Express 1hr service
- Electric van service.

[Find out more about service and repairs](#)



### › Flexible ways to pay and save

With fixed, transparent national pricing there are no surprises with our services and repairs – plus you can fix, spread and reduce your service and maintenance costs, and ease your cashflow at the same time, with a payment plan.

- Pay as You Go
- ServiceCare Maintenance
- ServiceCare Flex (specifically for fleets)
- ServiceCare Complete.

[Find out more about service options](#)

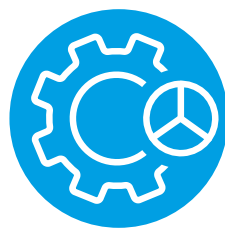

### › 3-year unlimited mileage warranty

Available on every new van, all service and maintenance – and any work required – is covered by your 3-year unlimited mileage warranty, and is only undertaken by Mercedes-Benz trained technicians using Mercedes-Benz GenuineParts.

[Find out more about warranties](#)



### › Free breakdown cover & roadside assistance\*

Every van comes with free Europe-wide breakdown cover – MobiloVan. And with 3 years' cover on new vehicles for driver mishaps, no one goes further to keep your business moving.

- Trained technicians using only Mercedes-Benz GenuineParts
- Forward travel of load and crew is covered
- Driver mishap cover for the first 3 years, including out of charge cover or empty fuel tanks.

[Find out more about MobiloVan](#)

\*For a full list of exclusions and all product terms please visit [www.mercedes-benz.co.uk/vans/en/Owners/MobiloVan](http://www.mercedes-benz.co.uk/vans/en/Owners/MobiloVan)

